



VALLA 35 D - TRX TRACKED CRANE Max Capacity 3,5 ton



ENGINE: diesel HP 50 - 4 cylinders, kW 37,5, water cooled.

TRANSMISSION: automatic, hydrostatic. Max speed 2,5 km/h.

FRAME: fabricated from preformed and welded steel plate with built-in counterweight. Standard carry deck.

TRACKED UNDERCARRIAGE: rubber tracks.

BOOM: fabricated from preformed and welded steel plate with 3 hydraulic telescoping sections fitted with adjustable nylon wear pads.

HYDRAULIC SYSTEM: gear pump , electric proportional distributor with radio remote control, filter, safety valves on all boom operations. Max hydraulic pressure 200 Bar.

TOTAL MACHINE WEIGHT: Kg. 3.200.

OPTIONAL EXTRAS: L.M.I. (electronic Load Moment Indicator), man bucket, hydraulic winch, hydraulic chain hoist, manual boom extension, hydraulic boom extension, LPG conversion.

Valla S.p.A.

Via Piacenza, 45 - 29010 Calendasco - Piacenza - ITALIA
Tel. 0039 0523 762025 - 762004 - Fax 0039 0523 760531
Internet: www.valla.com - email: info@valla.com

The crane complies with following international standards:

- I.S.P.E.S.L.
- DIN 15018 (1,3) - 15019 (1) class H 2 B3
- ANSI - 1994
- 98/37/CE
- 89/336/CEE

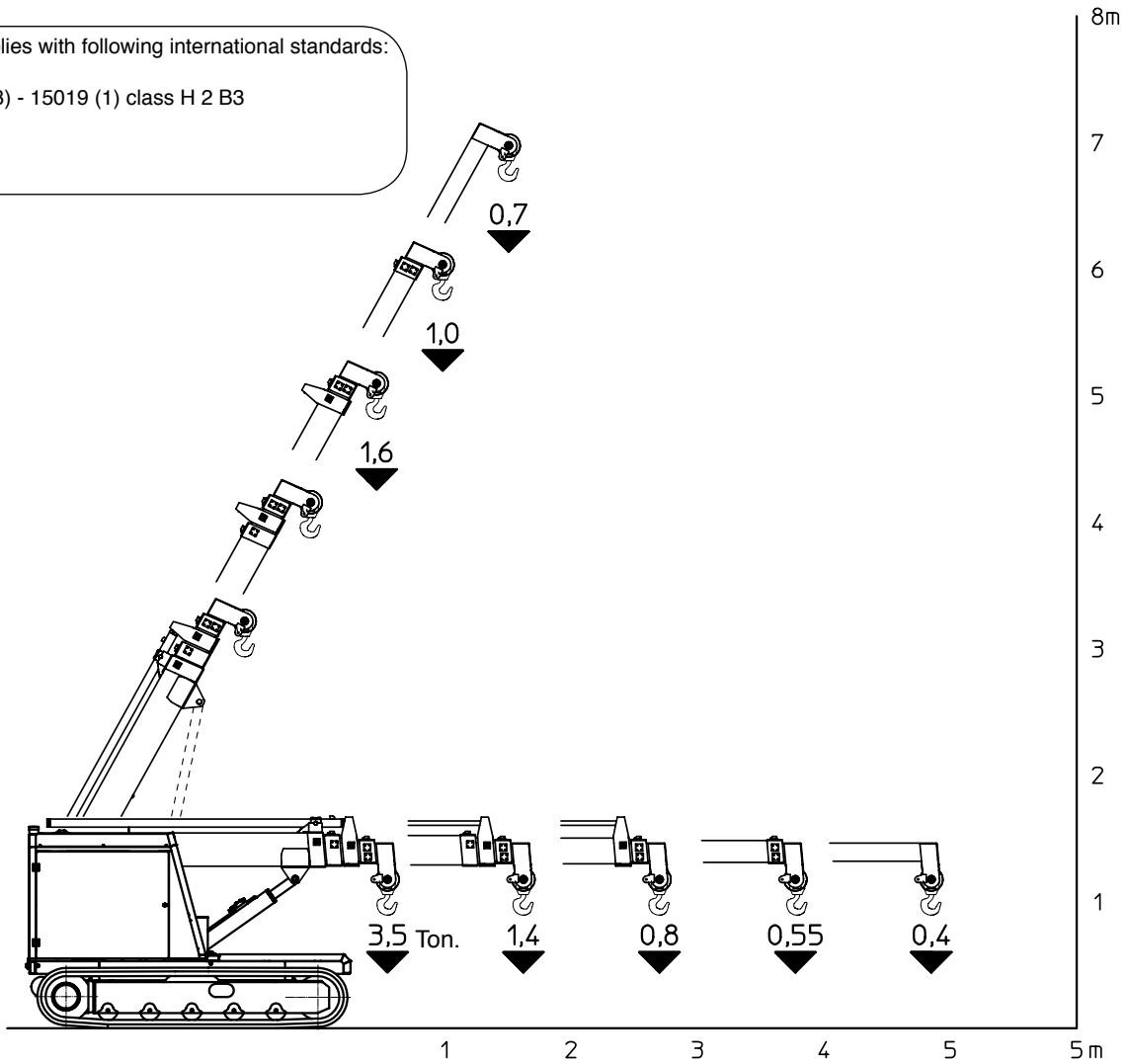

Mod. VALLA 35D TRX

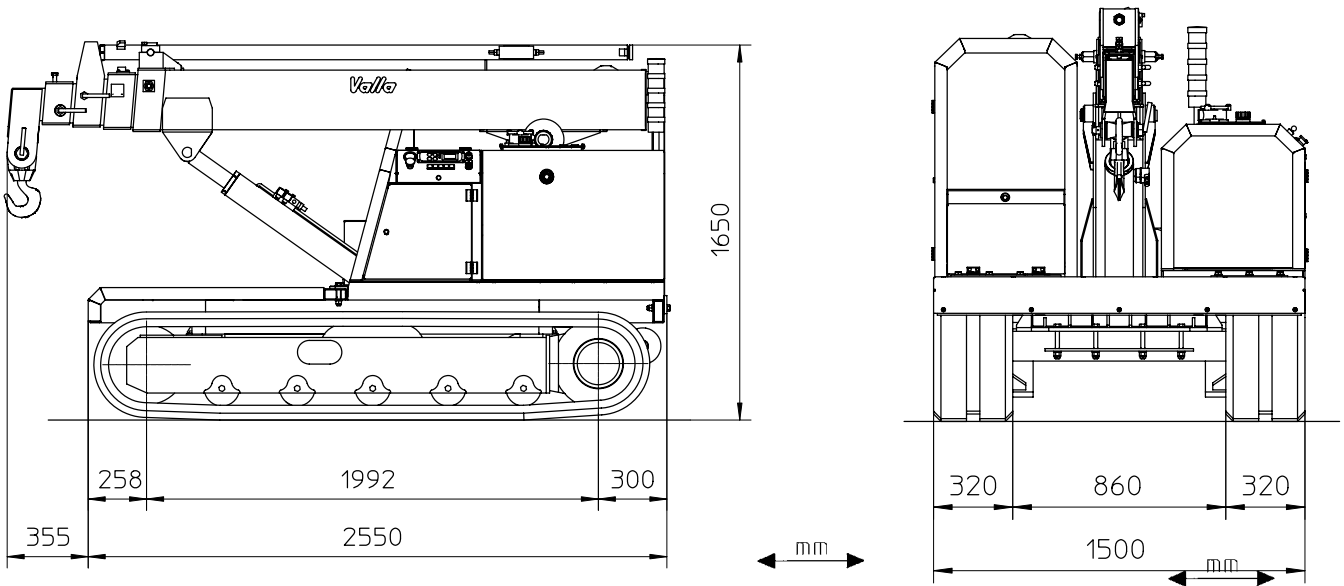

Valla S.p.A.

Via Piacenza, 45 - 29010 Calendasco - Piacenza - ITALIA
 Tel. 0039 0523 762025 - 762004 - Fax 0039 0523 760531
 Internet: www.valla.com - email: info@valla.com

