

MANISCOPIC

MRT 1635

M Series



- Lift height : 15.82 m
- Max. reach : 13.20 m
- Engine : 101 HP - 74.5 kw
- 4 wheel drive - 4 wheel steer
- Hydrostatic transmission



MANITOU

MRT 1635 M Series

ROTATION ON STABILISERS WITH FORKS

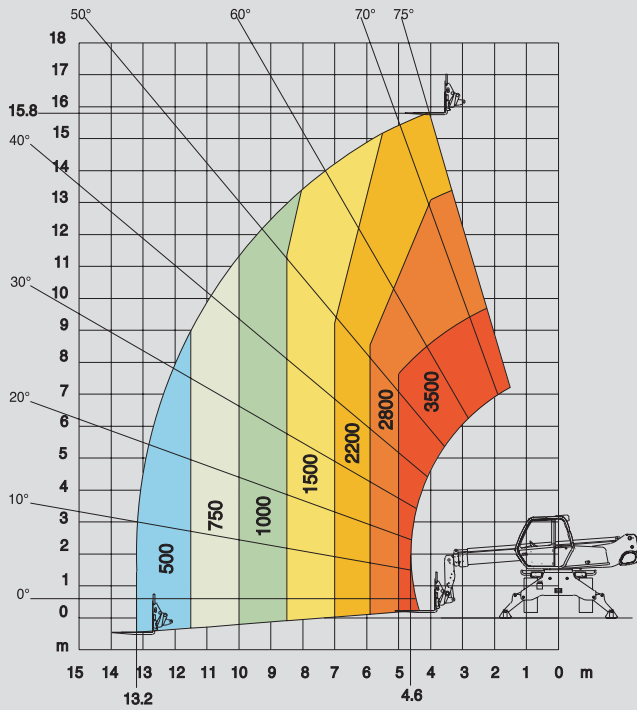

FRONTAL POSITION ON WHEELS WITH FORKS

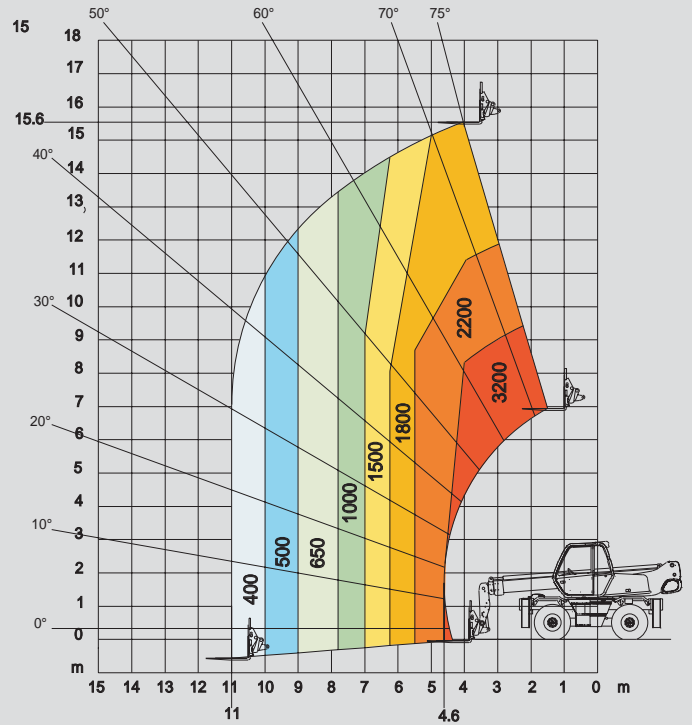

ROTATION ON WHEELS WITH FORKS

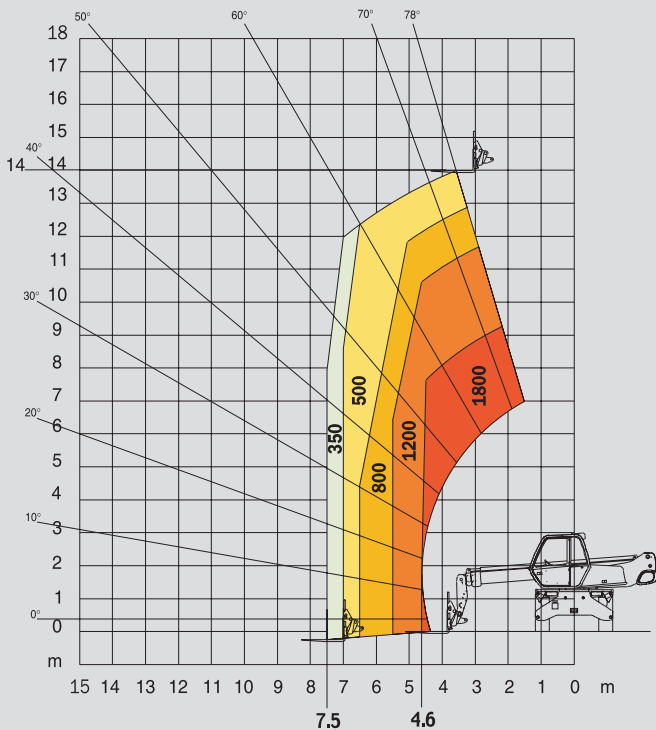

ROTATION ON STABILISERS WITH 3T WINCH

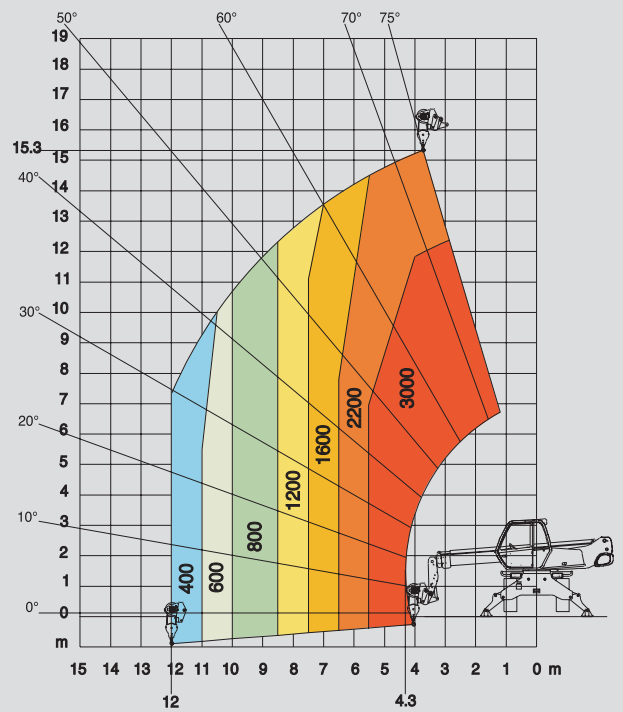

**ROTATION ON STABILISERS
WITH JIB P 600**

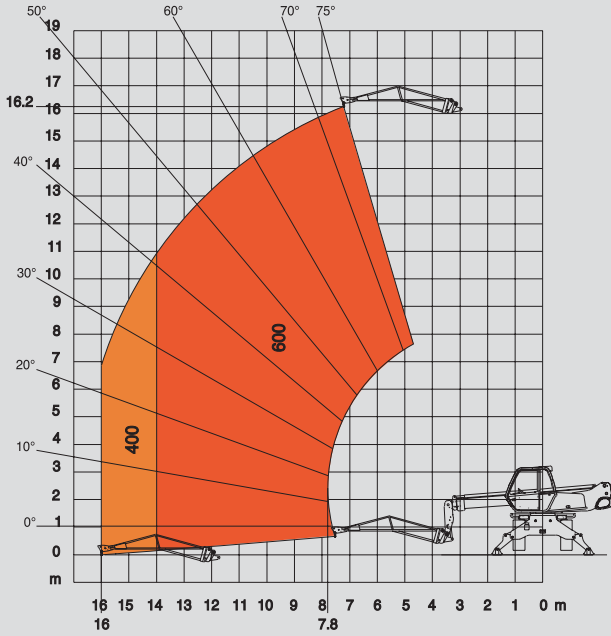

**ROTATION ON STABILISERS
WITH JIB P 1500**

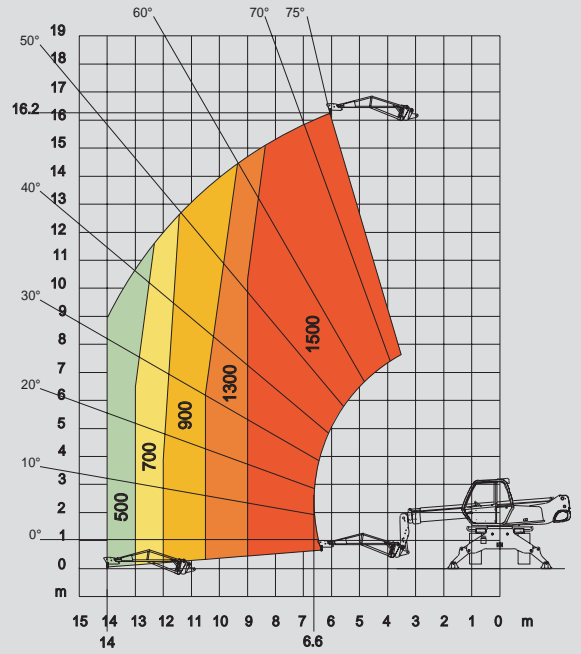

**ROTATION ON STABILISERS
WITH EXTENSIBLE PLATFORM 2,25/4 m**

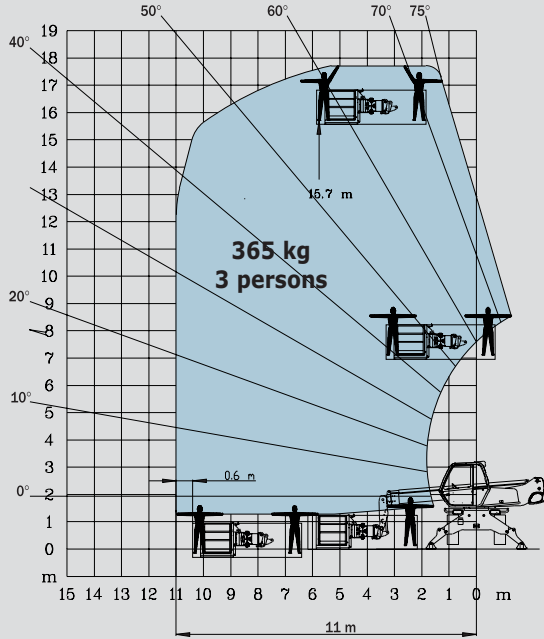

**ROTATION ON STABILISERS
WITH 1000 KG PLATFORM 2,25/4 m**

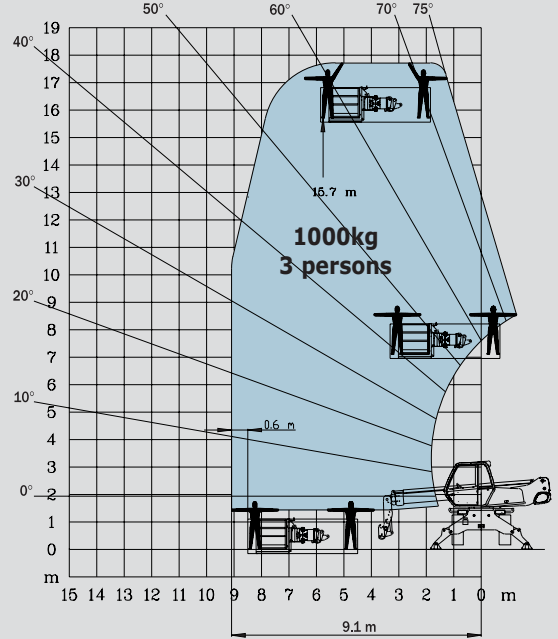

**ROTATION ON STABILISERS
WITH AERIAL JIB PLATFORM**

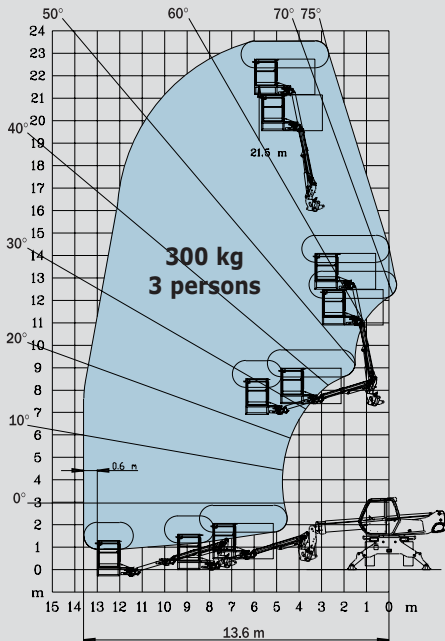

**Equipment customised
on order**

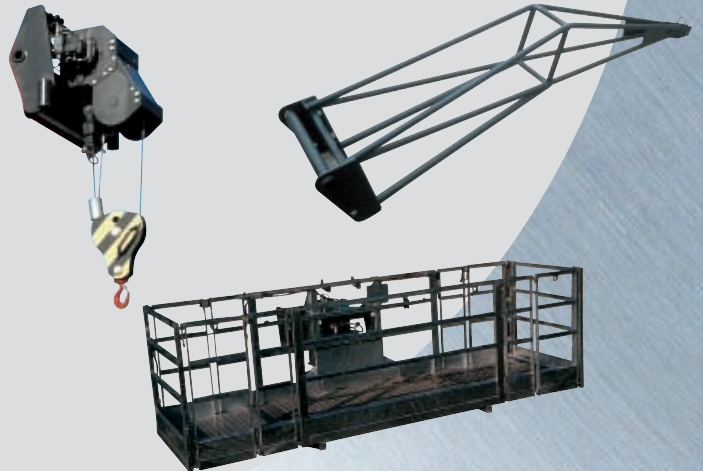

MRT 1635 *M Series*

 **Lift capacity** (on stabilisers)3500 kg
at 500 mm from forks heels

 **Lift height** :15.82 m

 **Tyres**
400/70 - 20 14 PR

 **Forks** (mm)
Length1200
Width x thickness125 X 45

 **Multidisc brakes** : hydraulically assisted on front axle
Negative parking brake

 **Engine PERKINS**
Type1104C.44 T
Capacity4 cyl. 4400 cm³
Power (ISO/TR 14396)101 HP/74.5 kw
at 2300 rpm
Water cooling
Direct injection

 **Transmission**hydrostatic
With automatic power regulation (hydraulic variable
displacement pump and motor)
Reversing shiftelectromagnetic
2 speed forward and reverse
Travel speed32 km/h*
*This speed may be limited by local regulations

 **Rear axle**
Automatic rear axle locking system
at a rotation over 15 °

 **4 stabilisers**
simultaneous or individually controlled

 **Rotation through 400°**
Turret mounted on a double slew ring

 **Hydraulics**
2 pumps gear type270 bars/115 l/mn

 **Control** : 2 electro proportional control joysticks for all
hydraulic movements

 **Capacities**
Cooling system15 l.
Engine oil8.1 l.
Hydraulic oil140 l.
Fuel tank130 l.

 **Weight unladen** (with forks)12955 kg
Overall width2.39 m
Overall height2.97 m
Overall length6.08 m
Ground clearance0.34 m
Drawbar pull8600 daN

 **Standard load moment indicator**
(mobile crane standards)

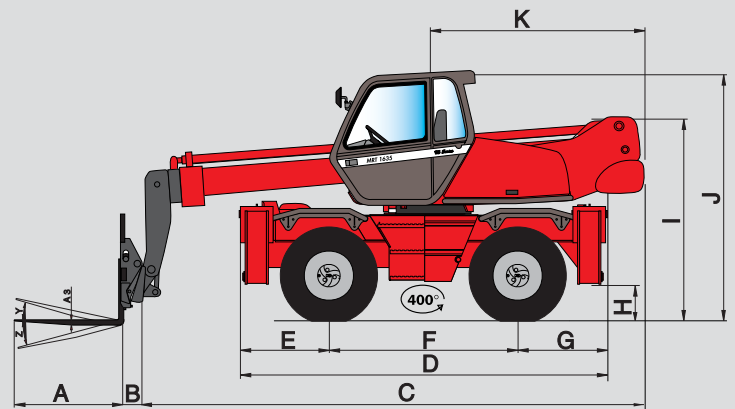

A	1200
A1	125
A2	1320
A3	45
B	290
C	6075
D	4330
E	1015
F	2320
G	1015
H	340
I	2375
J	2970
K	2485
L	1930
M	2390
N	3400
O	3800
P	160
Q	3900
R	3410
S	4000
T	3600
U	5520
V	950
Y	12°
Z	105°

mm

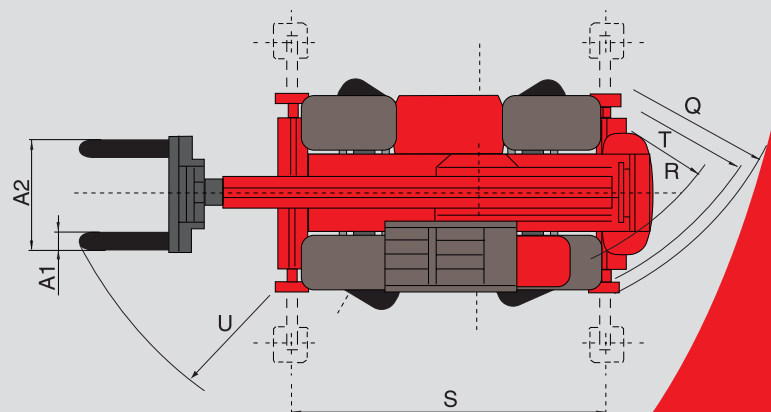
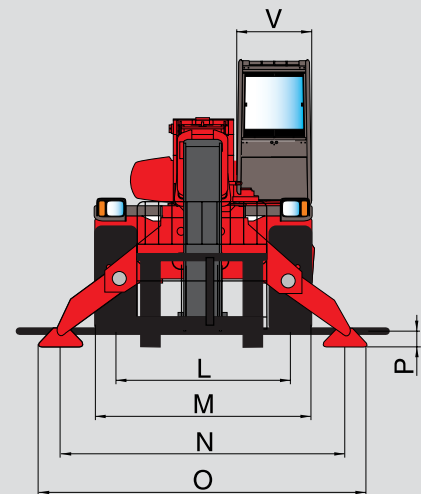

This publication in no way constitutes an offer and the company reserves the right to alter specification without prior notice.
The MANITOU models presented in this brochure can be supplied complete with optional equipment attachments.



MANITOU BF SA

B.P. 249 - 44158 Ancenis Cedex - France
Tél. : 33 2 40 09 10 11 / Export Department Fax : 33 2 40 09 10 97
www.manitou.com

700036EN

