

Technical sheet :

ULM 415 H



Capacities		Metric	Imperial
Max. capacity	Q	1500 kg	3307 lb
Max. lifting height	h3	4.30 m	14 ft 1 in
Max. outreach		2.62 m	8 ft 7 in
Reach at max. height		1 m	3 ft 3 in
Breakout force with bucket		1880 daN	1880 daN
Weight and dimensions			
Shipping mass (min. / max.)		2700 kg / 2900 kg	5952 lb / 6393 lb
Ground clearance	m4	0.29 m	11 in
Wheelbase	y	2.13 m	7 ft
Overall length to carriage (with hitch)	l11	3.47 m	11 ft 5 in
Overall length to carriage (without hitch)	l3	3.47 m	11 ft 5 in
Front overhang		0.77 m	2 ft 6 in
Overall width	b1	1.49 m	4 ft 11 in
Overall cab width	b4	0.66 m	2 ft 2 in
Overall height	h17	1.92 m	6 ft 4 in
Tilt-down angle	a5	116 °	116 °
Tilt-up angle	a4	23 °	23 °
External turning radius (over tyres)	Wa1	2.62 m	8 ft 7 in
Standard tires		CAMSO - MPT 552 - 10.0/75-15.3 124A8	CAMSO - MPT 552 - 10.0/75-15.3 124A8
Performances			
Lifting		8.80 s	8.80 s
Lowering		7 s	7 s
Extension		6.40 s	6.40 s
Retraction		4.30 s	4.30 s
Crowd		3.40 s	3.40 s
Dump		2.60 s	2.60 s
Engine			
Engine brand		Yanmar	Yanmar
Engine norm		Stage V / Tier 4 final	Stage V / Tier 4 final
Engine model		3TNV88C-DMU	3TNV88C-DMU
Number of cylinders - Capacity of cylinders		3 - 1642 cm ³	3 - 100 in ³
I.C. Engine power rating / Power (kW)		35.10 Hp / 26.20 kW	35.10 Hp / 26.20 kW
Max. torque / Engine rotation		105 Nm @1950 rpm	77 ft/lbs @1950 rpm
Drawbar pull (Laden)		2000 daN	2000 daN
Reversible fan		Option	Option
Engine cooling system		3 radiators (water + hydraulic oil + fuel)	3 radiators (water + hydraulic oil + fuel)
Transmission			
Transmission type		Hydrostatic	Hydrostatic
Number of gears (forward / reverse)		2 / 2	2 / 2
Max. travel speed (may vary according to applicable regulations)		25 km/h	16 mi/h
Differential lock		Limited slip differential on front and rear axles	Limited slip differential on front and rear axles
Parking brake		Automatic negative parking brake	Automatic negative parking brake
Service brake		Hydraulic servo brake	Hydraulic servo brake
Hydraulics			
Hydraulic pump type		Gear pump	Gear pump
Hydraulic flow - Pressure		48 l/min - 235 bar	13 US gpm - 3408 PSI
Flow sharing distributor		Standard	Standard
Tank capacities			
Hydraulic oil		39 l	10 US gal
Fuel tank		35 l	9 US gal
Noise and vibration			
Noise at driving position (LpA) tested following NF EN 12053 nom		76 dB	76 dB
Environmental noise (LwA)		104 dB	104 dB
Vibration to whole hand/arm		< 2.50 m/s ²	< 2.50 m/s ²
Miscellaneous			
Safety cab homologation		Cabin ROPS - FOPS Level 1	Cabin ROPS - FOPS Level 1
Controls		JSM	JSM

Options / Finishing

S : Standard / O : Optional / - : Not available

	Essential	Classic	Premium
Operator station			
"Harmony" screen	S	S	-
Automatic parking brake	S	S	-
Bluetooth USB car radio with integrated microphone (100 W)	O	O	-
Inner rear view mirror	O	S	-
Joystick Switch and Move (JSM)	S	S	-
Low frequency air suspension cloth-covered seat (GRAMMER)	O	O	-
Mechanical cloth-covered seat	S	-	O
Phone support	O	S	-
Rear window with de-icing	S	S	-
Tuner car radio (50 W)	O	S	-
Motorization/Power			
Continuous flow hydraulics	O	O	-
Speed limiter	O	O	-
Secondary functions			
1 pair of pre-fitted Double Action rear hydraulic couplers	O	S	-
Lighting			
Poultry farming blue lights (x2)	O	O	-
Security			
Sun visor on windshield and roof	O	S	-

ULM 415 H - Dimensional drawing

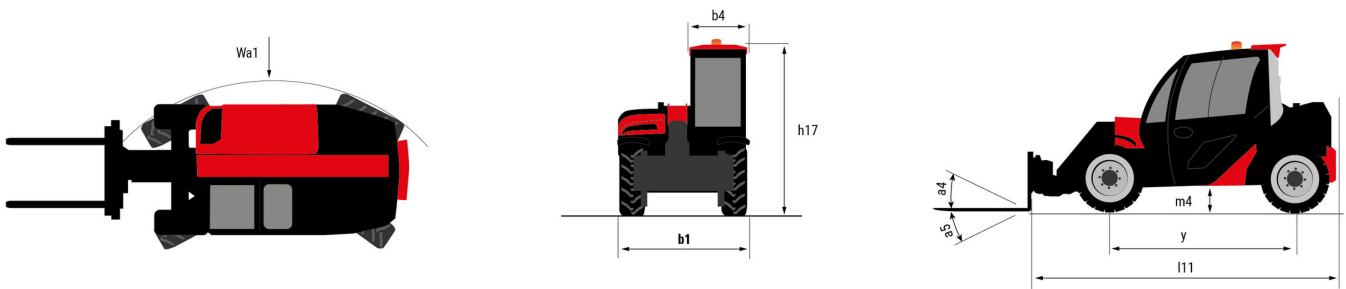

ULM 415 H - Load chart

Machine on tyres with forks Metric

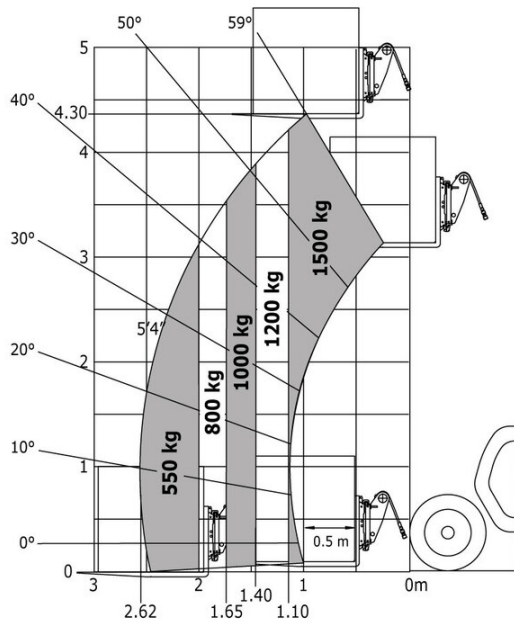

Machine on tyres with forks Imperial

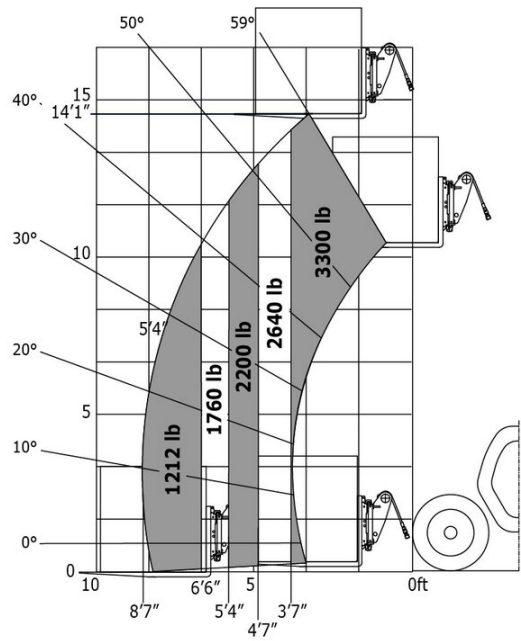



Head Office

B.P. 249 - 430 rue de l'Aubinière

44150 Ancenis Cedex - France

Tel: +33 (0)2 40 09 10 11 - Fax: +33 (0)2 40 09 10 97

www.manitou.com



This publication provides a description of the configuration versions and options for Manitou products, which may differ for equipment. The equipment presented in this brochure may be part of a series, as an option, or it may not be available, depending on the versions. Manitou reserves the right, at any time and without notice, to amend the specifications described and represented. The specifications provided do not bind the manufacturer. For more details, please contact your Manitou agent. This is not a contractually binding document. The presentation of the products is not contractually binding. List of specifications non-exhaustive. The logos as well as the visual identity of the company are owned by Manitou and cannot be used without authorisation. All rights reserved. The photos and diagrams contained in this brochure are only provided for consultation and information purposes.

MANITOU BF SA - Limited company with board of directors - Share capital: 39,668,399 euros - 857 802 508 RCS Nantes